

HECHT®

made for garden

9911

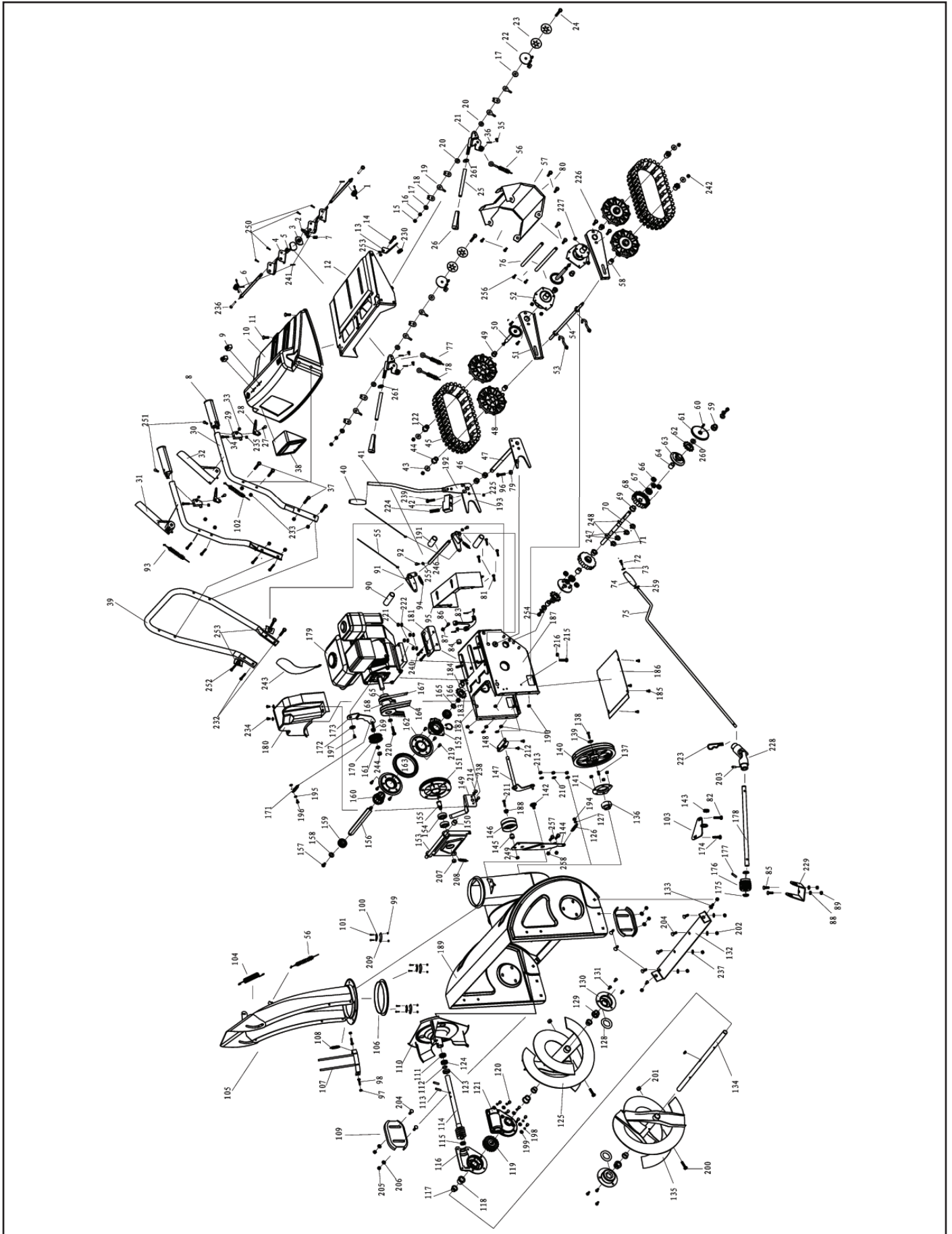

SNOW THROWER ZLST1101Q (11HP) SPARE PARTS LIST

No.	Code	English Name	QT
1	SX-11-001 SX-11-001a	handle spring	2
2	SX-11-002	clutch 1-2	1
3	SX-11-003	clutch 1-1	1 set
4	SX-11-004	Bracket 1-4	4
5	SX-11-005	clutch pin	1
6	SX-11-006	clutch 1-5	2
7	SX-11-007	spring 3	2
8	SX-11-008	Heated up handle sleeve	2
9	SX-11-009	Switch 2	
10		Plastic panel	1
11		Cross pan head screw 2	
12	SX-11-012-1B	steel plate joint drawing	1
13	SX-11-013	Steel plate	1
14		hexagonal Screw	1
15		lock nut	2
16		hexagonal screw	2
17		plain cushion	4
18	SJ-215	U fiche6	
19	SJ-224	gourd fiche	6
20		saddle flexibility washer	4
21	SJ-209	adjuster lever joint drawing	2
22	SJ-210-1	adjuster damp fixing plate	2
23	SJ-223	bowl shrapnel	4
24	SX-11-258	timing lever screw	2
25	SJ-209-4	adjusting joint rod	2
26	SJ-241	adjusting crank	2
27	SX-11-027	Screw 1	2
28	SX-11-028	Handle	2
29	SX-11-029	Handle holder	2
30	SX-11-030	Handle upper tube	2
31	SX-11-031-1A	crank joint drawing(right)	1
32	SX-11-032-1A	crank joint drawing(left)	1
33		Nut	2
34		hexagonal bolt	2
35	SJ-233	wire pin	5
36		hatch pin	5
37		Hexagon flange bolt	8
38		lamp	1
39	SX-11-039	Handle lower tube	1
40	SX-11-040	Handle sleeve	1
41	SX-11-041	Fork stick 3	1
42	SX-11-042		1
43		plain cushion	4
44	SX-11-044	wheel cover 2	2
45	SX-11-045	Pedrail 2	
46	SX-11-184	hexagonal sleeve	2
47	SX-11-047	Fork (Left)	1
48	SX-11-048	belt wheel	4
49	SX-11-049	Sleeve 3	4
50	SX-11-055B	Back chain wheel joint drawing	2

51	SX-11-051	Panel 32	
52	SX-11-052	Back wheel bracket	2 set
53	SX-11-053	Hook	2
54	SX-11-054	Bearing -0	1
55	SX-11-36C	stepped clutch wire	2
56	SX-11-36E	chute wire	1
57	SX-11-254	back cover board	1
58	SX-11-058	Front sleeve	2
59	SX-11-059	sleeve 2	2
60	SX-11-060	Pin key	1
61	SX-11-061A	Chain 28 gear	1
62	SX-11-062	Clutch 2-8	2
63	SX-11-063	Clutch 2-6	2
64	SX-11-064	Clutch 2-9	2
65	SJ-049 SJ	main sync wheel	1
66	SX-11-066	Clutch 2-3	6
67	SX-11-067	Clutch 2-2	2
68	SX-11-068	Clutch 2-4	2
69	SX-11-069	Clutch 2-5	2
70	SX-11-070	Clutch 2-1	1
71		Clutch circlip	3
72		Cross Screw	1
73		plain cushion	1
74	XA-04-105	Crank sleeve	1
75	SX-11-075	Crank -1	1
76	SX-11-248	rear wheel stand bar	2
77	SX-11-36A-2	Forward wire	1
78	SX-11-36A-1	reverse wire	1
79		lock nut	1
80		hexagonal flange bolt	4
81		Hexagon socket bolt	4
82		hexagonal flange bolt	1
83	SJ-211	limit frame jointing drawing	1
84	SX-11-147D	11P separate sleeve	1
85		Cup head square neck screw	2
86		hexagonal bolt	1
87		lock nut	1
88		plain cushion	2
89		lock nut	2
90	SX-11-090	Separate sleeve 3	2
91	SX-11-091	Paw	2
92		hexagonal flange bolt	2
93	SX-11-36D	stepped wire	1
94	SX-11-094	limited frame spring	2
95	SX-11-253	back cover board 1	1
96		hexagonal bolt 1	
97		lock nut	2
98		hexagonal Screw	2
99		lock nut	6
100	SJ-021C	Chute mat	3
101		hexagonal screw	6
102	SX-11-36B	auger wire	1
103	SX-11-260	Crank below bracket welding drawing	1

	SX-11-261	Crank below bracket	1
104	SJ-226	chute extension spring	1
105	SX-11-105-1 SX-11-106-1	chute assembly	1 set
106	SJ-237	chute pedestal plastic circle	1
107	SJ-012	Discharge chute accessories	1 set
108	SJ-036	Discharge chute spring	1
109	SJ-111	slide	2
110	SJ-001	Fan	1 set
111		oil seal	1
112	SJ-057	Washer1	
113		Pin key	1
114	SX-11-114	Drive worm shaft	1
115	SX-11-115	Deep slot bearing	1
116	SJ-101	Pedestal	1
117	SJ-019	Drive shaft sheath	2
118	SJ-108	Output shaft	2
119	SJ-038	Worm wheel	1
120		hexagonal Screw	7
121	SJ-101A	Upper Pedestal	1
122	SX-11-122	Back trye	2
123	SX-11-123	Deep slot bearing	1
124	SX-11-124	One direction thrust bearing	1
125	SX-11-125	right Auger	1
126	SJ-037	Fixing plate spring 5	1
127		plain cushion	1
128		Washer	2
129	SJ-020	Sleeve	2
130	SJ-024	Bearing cover	2
131		hexagonal Screw	6
132	SX-11-132	Shave plate	1
133		Screw	2
134	SX-11-134	Auger output shaft	1
135	SX-11-135	left Auger	1
136		Bearing	1
137		Square key	1
138		hexagonal Screw	1
139		plain cushion	1
140	SX-11-140	pulley	1
141	SJ-004	Rockered cover	1
142	SJ-050	Screw -1	1
143	SJ-239	washer	1
144	SX-11-144	Fixing plate 3	1
145	SJ-008B	Washer	1
146	SJ-008	Wheel (add bearing)	1
147	SX-11-147	Gearlever	1
148	SX-11-148	Orthogonal Iron	1
149	SX-11-149	pulley plate -1	2
150	SJ-107	Washer	1
151	SJ-010A	Wheel	1
152	SJ-013B	Gear wheel cover	1
153	SJ-007	Wheel Bracket	1
154		Bearing	2
155	SJ-010B	Driving belt wheel axle	2

156	SX-11-156	Hexagonal shaft	1
157		hexagonal flange bolt	1
158		Mat	1
159		Bearing	2
160	SJ-013C	Gear wheel	1
161	SJ-008C	Washer	2
162	SJ-013A	Gear wheel washer	2
163	SJ-013D	Rubber circle	1
164	BZ-035	V-belt	2
165		Mat	1
166		nut	2
167	BZ-038	5M synchro-belt	1
168	SX-11-168	main pulley	1 set
169	SX-11-170B	Mat	1
170	SX-11-170	Small Tension pulley (+double row angular contact ball bearing)	1
171	SX-11-171	Small Tension pulley spring	1
172	SJ-046	Tension convex washer	1
173	SX-11-173	Small Tension pulley	1
174		hexagonal flange bolt	1
175	SJ-238	washer	2
176	SX-11-255	spiral gear	1
177		Spring-type straight pin	1
178	SX-11-084-1	chute rocker1	1
179		engine	1
180	SX-11-180	pulley cover	1
181	SX-11-181	Gear plate	1
182		circlip	1
183	SX-11-183	sprocket wheel	1
184	SX-11-184	Hexangular Bearing	1
185		Hexangula Screw	4
186	SX-11-186	Blower cover board	1
187	SX-11-187	Gear Box	1
188	SJ-025B	Mat	1
189	SX-11-189	Steel Cover	1
190		lock nut	6
		plain cushion	6
191	SX-11-191	Separate sleeve 1	1
192	SX-11-192	Fork stick -1	1
193	SX-11-193	Right fork stick	2
194		lock nut	1
195		plain cushion	2
196		hexagonal Screw	1
197		hexagonal Screw	1
198		Spring Mat	7
199		Plain washer	7
200	SJ-070	Auger bolt	2
201		lock nut	2
202		lock nut	6
203		Spring-type straight pin	1
204		Cup head square neck screw	8
205		lock nut	2
206		Mat	2
207		lock nut	1

208	SJ-069	Wheel bracket spring	1
209	SJ-021	chute sheeting	3
210		plain cushion	6
211		hexagonal screw	1
212		hexagonal screw	2
213		lock nut	6
214		hexagonal screw	2
215		hexagonal screw	1
216		lock nut	1
219		hexagonal screw	6
220		hexagonal screw	1
		plain cushion	1
221		lock nut	4
222		plain cushion	4
223		pin	1
224	SX-11-224	clevis bolt	1
225		lock nut	1
226	SX-11-242	Pedrail bracket bolt	4
227		lock nut	4
228	SX-11-257	Cardan	1
229	SX-11-259	bracket	1
230	SX-11-230	Chute rocker sleeve	1
232		hexagonal flange screw	4
233		lock nut	8
234		hexagonal screw	2
		gasket	2
235		lock nut	2
236	SX-11-006-1A	screw	2
237		plain cushion	4
238		plain cushion	2
239		hexagonal flange screw	1
240		hexagonal flange screw	2
241		hatch pin	3
242		lock nut	4
243		key chain	1
244		lock nut	1
245		plain cushion	1
246	SX-11-246	claw axle	1
247		snap spring	2
248		Semicircular key	2
249		lock nut	1
250		hexagonal screw	4
251		cross bolt	2
252		hexagonal flange bolt	2
253	SJ-028	handle washer	2
254		hexagonal bolt	2
		spring lock washers	2
		plain cushion	2
255		plain cushion	2
256		hexagonal flange bolt	4
257	SJ-23-25	Tension screw	2
258		lock nut	2
259		battery	1

260		battery cover	2
261		fix screw	2
1		anchor nut	1
		charge station	1
		charge station fix board	1
		charge station fix board spacer	1
2		charge station fix board lock screw	1
	SX-11-256		1
	SX-11-256A	charge station lock screw	1

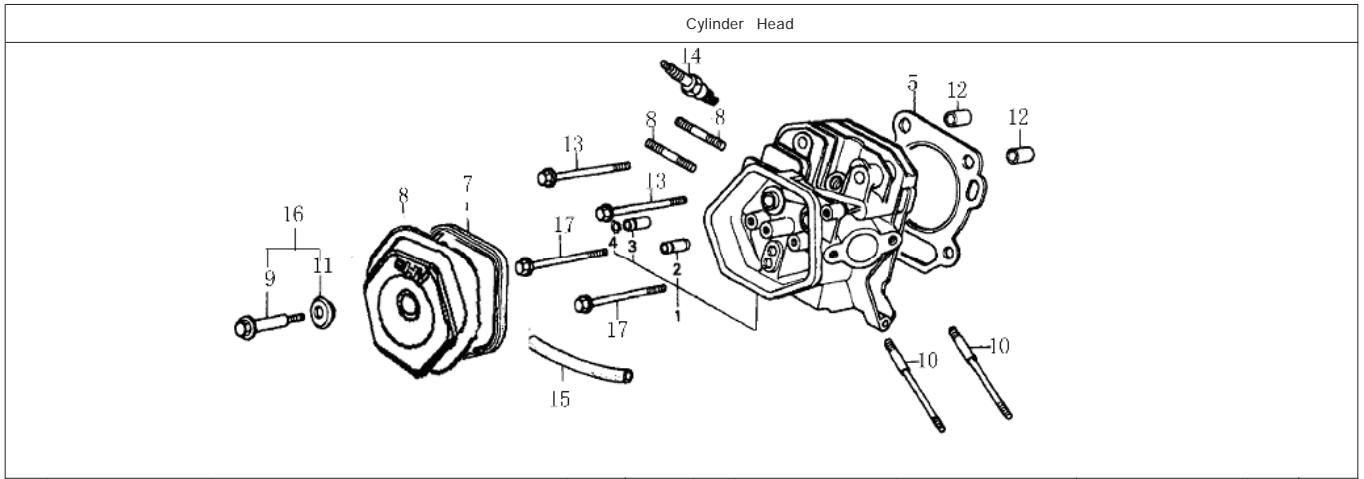

No.	Part No.	Description English	QTY.		No.	Part No.	Description English	QTY.	
			182F(E)	188F(E)				182F(E)	188F(E)
1	1122B-PB50-0000	HEAD COMP., CYLINDER	1	1	13	B0578900100080700	BOLT, FLANGE, 10X80	2	2
2	11246-PB52-0000	GUIDE, IN. VALVE	1	1	14	81300-KB01-0000	PLUG, SPARK	1	1
3	11247-PB52-0000	GUIDE, EX. VALVE	1	1	15	12104-MB30-0000	BREATHER HOSE	1	1
4	B000930006000000B	CLIP, VALVE GUIDE, 6 6	1	1	16	91132-1060-06170B	BOLT COMP	1	1
5	9022B-PB50-0000	GASKET, CYLINDER HEAD	1	-	17	B057890E10008070N	BOLT, FLANGE, 10X80	2	2
	9022B-QB60-0000	GASKET, CYLINDER HEAD	-	1					
6	11221-MB30-0100	COVER COMP., HEAD	1	1					
7	90229-MB30-0000	GASKET, HEAD COVER	1	1					
8	91138-MB30-0000	STUD, 8X25	2	2					
9	91133-MB30-0000	BOLT, HEAD COVER	1	1					
10	91127-PB50-0000	STUD, M6-8 '134	2	2					
11	91135-MB30-0000	WASHER, HEAD COVER	1	1					
12	91521-12002000000	PIN, DOWEL, 12X20	2	2					

1

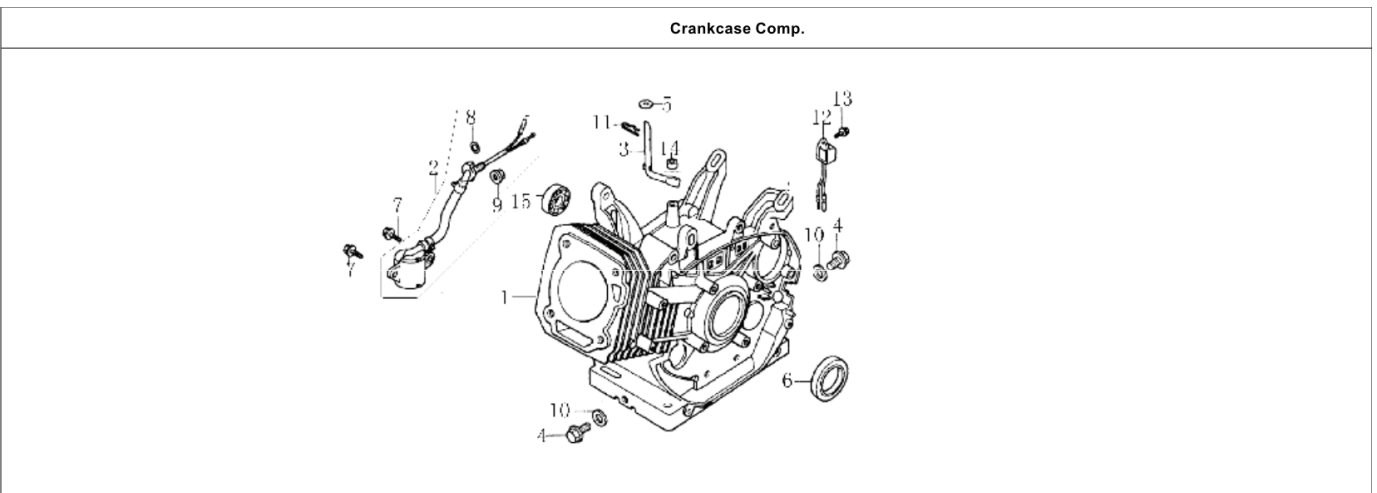

No.	Part No.	Description English	QTY.		No.	Part No.	Description English	QTY.	
			182F(E)	188F(E)				182F(E)	188F(E)
1	12007-PB50-0000	CRANKCASE COMP.	1	-	14	T1102008001400500	OIL SEAL, $\phi 8 \times \phi 14 \times 5$	1	1
	12007-QB60-0000	CRANKCASE COMP.	-	1	15	92102-00000006202	BEARING 6202	1	1
2	87400-MB30-0100	OIL SENSOR	1	1					
3	24605-PB52-0000	GOVERNOR ARM	1	1					
4	91103-MB30-0000	BOLT, DRAIN PLUG	2	2					
5	91306-90820817000	WASHER, $8 \times 217 \times 0.8$	1	1					
6	T1105035005200800	OIL SEAL, $35 \times 52 \times 8$	1	1					
7	B057890006001670B	BOLT, FLANGE, 6X16	2	2					
8	90101-1009000018	O-RING, 9MM	1	1					
9	B061770110000060B	NUT, FLANGE, 10MM	1	1					
10	91302-91202020000	WASHER, 12MM	2	2					
11	24606-MB30-0000	PIN, LOCK	1	1					
12	87420-KB01-0000	AMPLIFIER	1	1					
13	B057890006001070B	BOLT, FLANGE, 6X10	1	1					

2

Crankcase Comp.

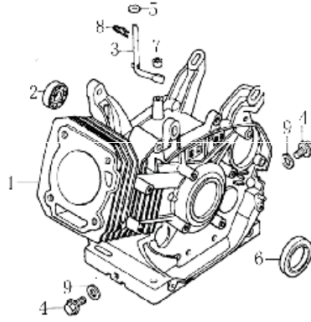

No.	Part No.	Description		QTY.		No.	Part No.	Description		QTY.	
		English		182F(E)	188F(E)			English		182F(E)	188F(E)
1	12007-PB50-0100	CRANKCASE COMP.		1	-						
	12007-QB60-0100	CRANKCASE COMP.		-	1						
2	92102-0000006202	BEARING6202		1	1						
3	24605-PB52-0000	GOVERNOR ARM		1	1						
4	91103-MB30-0000	BOLT, DRAIN PLUG		2	2						
5	91306-90820817000	WASHER, 8x217x 0,8		1	1						
6	T1105035005200800	OIL SEAL, 30x46x 8		1	1						
7	T1102008001400500	OIL SEAL, φ8xφ 14x		5	1	1					
8	24606-MB30-0000	PIN, LOCK		1	1						
9	91302-91202020000	WASHER, 12MM		2	2						

3

Crankcase Cover

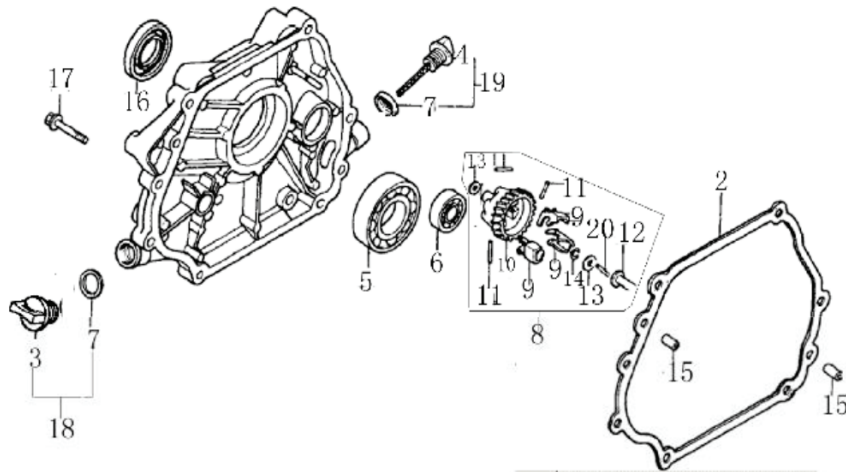

No.	Part No.	Description		QTY.		No.	Part No.	Description		QTY.	
		English		182F(E)	188F(E)			English		182F(E)	188F(E)
1	12301-PB50-0000	LEFT COVER ,CRANKCASE		1	1	14	24623-MB30-0000	CLIP , GOVERNOR HOLDER		1	1
2	90208-PB52-0000	GASKET,CASE COVER		1	1	15	91521-08001200000	PIN, DOWEL, 8 12		2	2
3	14315-MB30-0000	PLUG,OIL FILLER		1	1	16	T1105035005200800	OIL SEAL, 30x52x 8		1	1
4	14312-MB32-0000	DIPSTICK		1	-	17	B057890008003870B	BOLT, FLANGE, 8X38		7	7
	14312-QB62-0200	DIPSTICK		-	1	18	14311-MB30-0000	OIL FILLER PULG COMP		1	1
5	92102-0000006207	BEARING6207		1	1	19	14301-MB32-0000	DIPSTICK COMP		1	1
6	92102-0000006202	BEARING6202		1	1	20	24621-PB52-0000	SHAFT		1	1
7	14303-PB52-0000	O-RING		2	2						
8	24620-PB52-0000	GOVERNOR GEAR KIT		1	1						
9	24624-PB52-0000	WEIGHT, GOVERNOR		3	3						
10	24626-PB50-0000	SLAVE GEAR, GOVERNOR		1	1						
11	24625-PB52-0000	PIN, GOVERNOR WEIGHT		3	3						
12	24622-PB52-0000	SLIDER, GOVERNOR		1	1						
13	24628-PB50-0000	WASHER		2	2						

4

Crankshaft

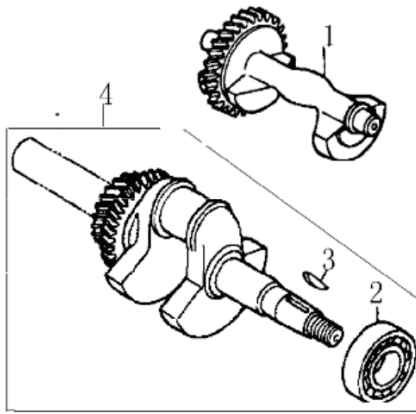

No.	Part No.	Description		QTY.		No.	Part No.	Description		QTY.	
		English		182F(E)	188F(E)			English		182F(E)	188F(E)
1	13300-PB52-0000	BALANCEABLE SHAFT ASSY.1			1						
2	92102-00000006207	BEARING6207		1	1						
3	91601-MB30-0000	SPECIAL WOODRUFF KEY		1	1						
4	13230-PB52-0100	CRANSHAFT ASSY.		1	1						

Piston/Connecting rod Comp.

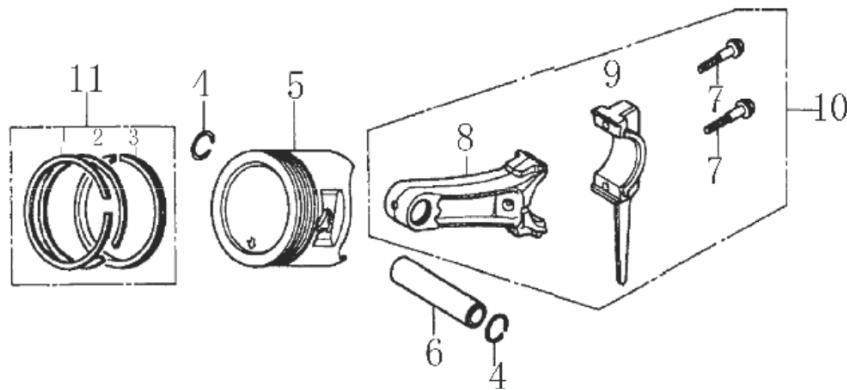

No.	Part No.	Description		QTY.		No.	Part No.	Description		QTY.	
		English		182F(E)	188F(E)			English		182F(E)	188F(E)
1	13103-PB52-0000	FIRST RING SET,PISTON		1	-						
	13103-QB62-0000	FIRST RING SET,PISTON		-	1						
2	13104-PB52-0000	SECOND RING SET,PISTON		1	-						
	13104-QB62-0000	SECOND RING SET,PISTON		-	1						
3	13120-PB52-0000	OIL RING SET,PISTON		1	-						
	13120-QB62-0000	OIL RING SET,PISTON		-	1						
4	13105-PB52-0000	CLIP,PISTON PIN		2	2						
5	13101-PB52-0000	PISTON		1	-						
	13101-QB62-0000	PISTON		-	1						
6	13102-PB52-0000	PIN,PISTON		1	1						
7	13215-MB30-0000	BOLT,CONNECTING ROB		2	2						
8	13204-PB52-0000	CONNECTING ROD		1	1						
9	13214-PB52-0000	COVER,CONNECTING ROD		1	1						
10	13220-PB52-0000	CONNECTING ROD COMP		1	1						
11	1310A-PB52-0000	RING SET COMP,PISTON		1	1						

Gas Distribution System

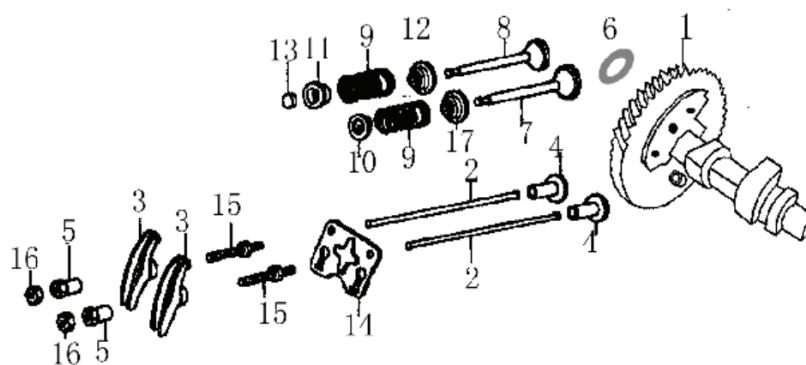

No.	Part No.	Description		QTY.		No.	Part No.	Description		QTY.	
		English		182F(E)	188F(E)			English		182F(E)	188F(E)
1	15100-PB52-0000	CAMSHAFT ASSY		1	-	14	15406-MB30-0000	PLATE,PUSH ROD GUIDE1		1	
	15100-QB62-0000	CAMSHAFT ASSY		-	1	15	15415-MB30-0000	BOLT,PIVOT		2	2
2	15321-PB52-0000	ROD,PUSH		2	2	16	15414-KB01-0000	NUT,PIVOT ADJUSTING		2	2
3	15401-MB30-0000	ARM,VALVE ROCKER		2	2	17	1572B-MB30-0000	VALVE SEAL		1	1
4	15002-MB30-0000	LIFTER,VALVE		2	2						
5	15403-KB01-0000	ADJUSTING NUT , VALVE		2	2						
6	91306-91600324X0E	WASHER		1	1						
7	15701-PB52-0000	VALVE,INLET		1	1						
8	15702-PB52-0000	VALVE,EXHAUST		1	1						
9	15703-MB30-0000	SPRING,VALVE		2	2						
10	15711-MB30-0000	INTAKE VALVE SPRING SEAT		1	1						
11	15712-MB30-0000	EXHAUST VALVE SPRING SEAT		1	1						
12	15705-MB30-0000	SEAT,VALVE SPRING		1	1						
13	15713-MB30-0000	ADJUSTIER,EX.VALVE		1	1						

7

Recoil Starter

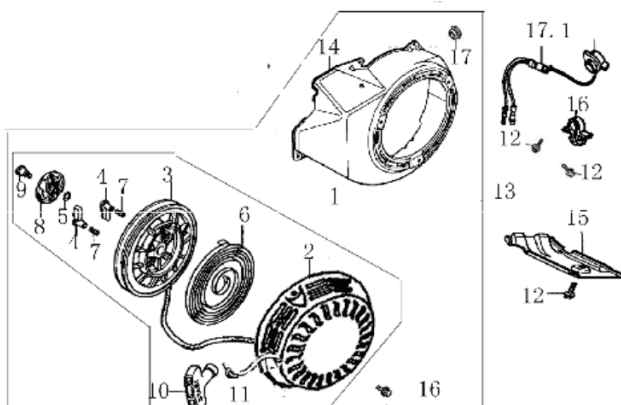

No.	Part No.	Description		QTY.		No.	Part No.	Description		QTY.	
		English		182F(E)	188F(E)			English		182F(E)	188F(E)
1	21510-PB50-0000	STARTER COMPRECOIL		1	1	15	19113-PB50-0000	SIDE PLATE		1	1
2	21519-PB50-0000	COVER COMP.RECOIL STARTER		1	1	16	10064-MB30-0000	WIRE CLIP		1	1
3	21511-PB50-0000	REEL, RECOIL STARTER		1	1	17	19111-KB03-0000	GROMMET,DRAIN HOLE		1	1
4	21512-MB30-0000	RATCHETSTARTER		2	2	17.1	72380-KB01-0000	SWITCH ASSYENGINE STOP		1	1
5	21518-MB30-0000	SPRING		1	1	18	B057870006001070B	BOLT, FLANGEM6x10		3	3
6	21514-MB30-0000	SPRING , STARTER RETURN		1	1						
7	21515-MB30-0000	SPRING RATCHET		2	2						
8	21513-MB30-0000	RATCHETGUIDE		1	1						
9	21521-KB01-0000	BOLT,SETTING		1	1						
10	21516-MB30-0000	HANDLESTARTER		1	1						
11	21517-MB30-0000	ROPE RECOIL STARTER		1	1						
12	B057890006001270B	BOLT,FLANGE,M6X12		6	6						
13	21500-PB52-0000	RECOIL STARTER		1	1						
14	21530-PB52-0300	FAN COVER COMP		1	1						

8

) Carburetor

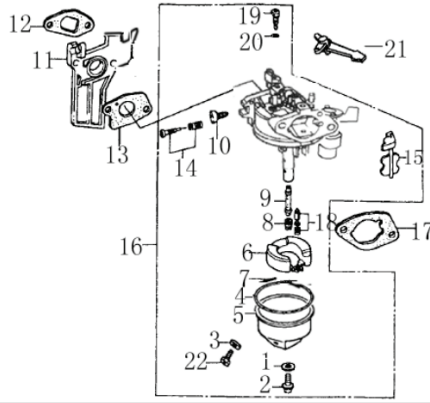

No.	Part No.	Description		QTY.		No.	Part No.	Description		QTY.	
		English		182F(E)	188F(E)			English		182F(E)	188F(E)
1	17189-KB01-0000	GASKET		1	1	14	17130-PB50-0000	SCREW SET PILOT		1	1
2	17159-BP50-0000	SCREW		1	1	15	17154-PB52-0000	CHOKE SET		1	1
3	17188-KB01-0000	GASKET		1	1	16	17100-PB50-0000	CARBURETOR Assy.		1	-
4	17157-PB52-0000	GASKET		1	1		17100-QB60-0000	CARBURETOR Assy.		-	1
5	17153-PB52-0000	CHAMBER SET FLOAT		1	1	17	17113-PB50-0000	PACKING AIR CLEANER		1	1
6	17152-PB52-0000	FLOAT SET		1	1	18	17170-PB50-0000	VALVE SET FLOAT		1	1
7	17171-PB52-0000	SHAFT FLOAT		1	1	19	17161-PB52-0000	JET SET, PILOT		1	1
8	17162-QB60-0000	JET , MAIN		1	1	20	17194-KB01-0000	CARBURETOR PACKING		1	1
9	17168-QB62-0000	NOZZLE MAIN		1	1	21	17163-PB60-0000	LEVER COMPCHOKE		1	1
10	17158-PB52-0000	SCREW THROTTLE ADJUSTING		1	1	22	17186-PB50-0000	DRAIN SCREW SET		1	1
11	17112-PB50-0000	INSULATOR, CARBURETOR		1	1						
12	17107-PB50-0000	PACKING INSULATOR		1	1						
13	17182-PB52-0000	PACKING , CARBURETOR		1	-						
	17182-QB60-0000	PACKING , CARBURETOR		-	1						

9

Ignition

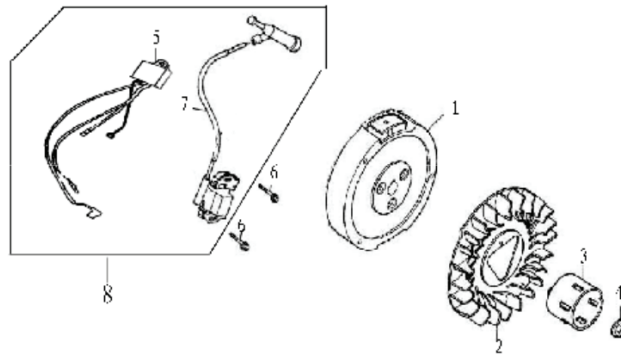

No.	Part No.	Description		QTY.		No.	Part No.	Description		QTY.	
		English		182F(E)	188F(E)			English		182F(E)	188F(E)
1	82150-PB52-0000	FLYWHEEL, COMP.		1/-	1/-						
2	19102-PB52-0000	FAN, COOLING		1	1						
3	21520-PB52-0000	PULLEY, STARTER		1	1						
4	B061770116000060B	NUT, FLANGE, M10.5		1	1						
5	09003-KB01-0000	TRIGGER, IGNITION		1	1						
6	B057890006002870B	BOLT, FLANGE M6x28		2	2						
7	81100-PB52-0000	HIGH VOLTAGE BOX		1	1						
8	81200-PB52-0001	COIL ASSAY, IGNITION		1	1						

10

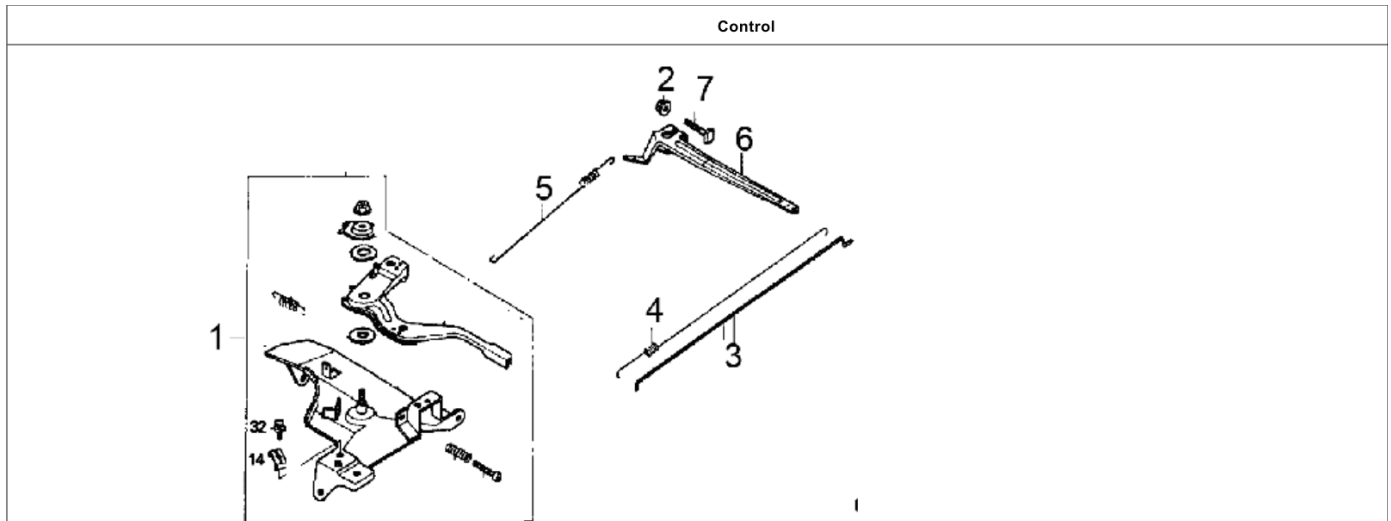

No.	Part No.	Description		QTY.		No.	Part No.	Description		QTY.	
		English		182F(E)	188F(E)			English		182F(E)	188F(E)
1	24610-PB50-0000	CONTROL ASSY		1	1						
2	B061770106000060B-1	NUT, FLANGEM6		1	1						
3	24604-PB52-0000	ROD GOVERNOR		1	1						
4	24603-MB30-0000	SPRING, THROTTLE RETURN1			1						
5	24602-PB52-0000	SPRING, GOVERNOR		1	1						
6	24607-PB52-0000	ARM, GOVERNOR		1	1						
7	91121-1060-02120B	BOLT, FLANGEM6x21		1	1						

11

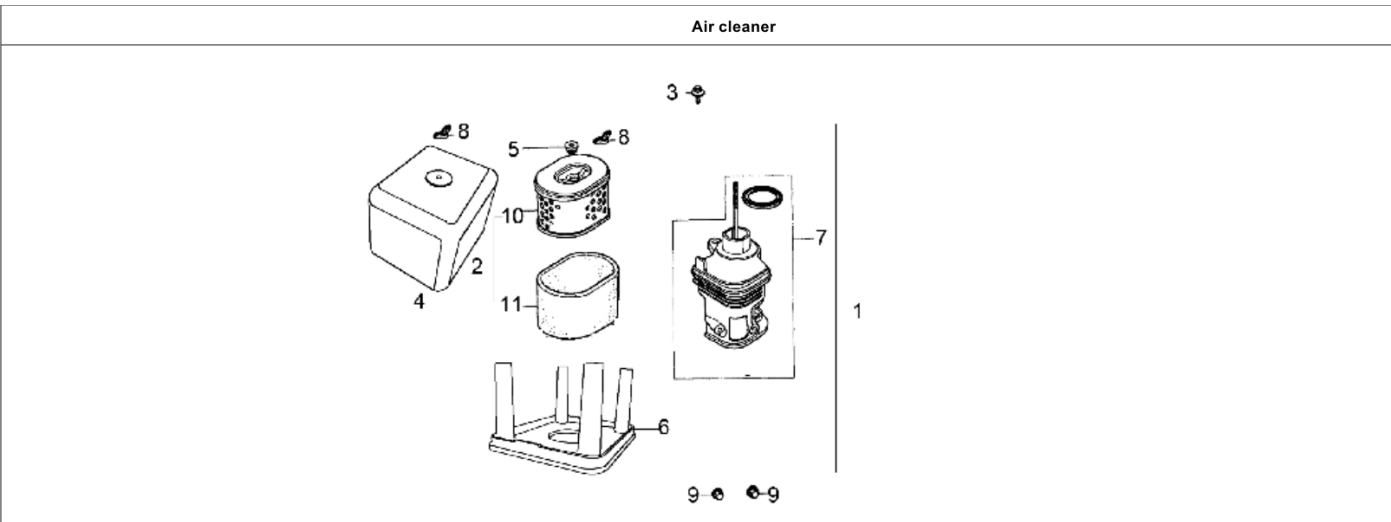

No.	Part No.	Description		QTY.		No.	Part No.	Description		QTY.	
		English		182F(E)	188F(E)			English		182F(E)	188F(E)
1	16100-PB50-0000	AIR CLEANER ASSY.		1	1						
2	16101-PB50-0000	ELEMENT AIR CLEANER		1	1						
3	B057890006002070B	BOLT, FLANGE6X20		1	1						
4	16105-PB52-0100	COVER AIR CLEANER		1	1						
5	16118-KB01-0000	GROMMET AIR CLEANER		1	1						
6	16110-KB01-0000	SILENCER PLATE		1	1						
7	16127-PB50-0000	ELBOW COMM AIR CLEANER		1	1						
8	16153-KB01-0000	BUTTERFLY NUT		2	2						
9	B061700006000060B	NUT, FLANGEM6		2	2						
10	16108-PB50-0000	PAPER ELEMENT ,AIR CLEANER		1	1						
11	16104-PB50-0000	SPENGE ELEMENT ,AIR CLEANER		1	1						

12

Muffler Comp

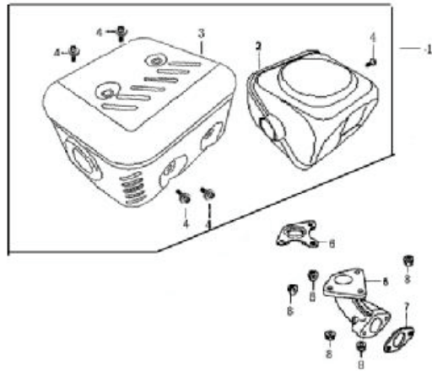

No.	Part No.	Description		QTY.		No.	Part No.	Description		QTY.	
		English		182F(E)	188F(E)			English		182F(E)	188F(E)
1	18000-PB50-0000	MUFFLER COMP.		1	1						
2	18004-PB50-0000	MUFFLER BODY		1	1						
3	18040-PB50-0000	SHIELD MUFFLER		1	1						
4	B057830004000870B	BOLT, M4×8		4	4						
5	18100-MB30-0000	EX. , PIPE		1	1						
6	18066-MB30-0000	GASKET,EX.PIPE		1	1						
7	18007-MB30-0000	GASKET,MUFFLER		1	1						
8	B061770108000060B	NUT,FLANGE,8MM		5	5						

13

Fuel Tank

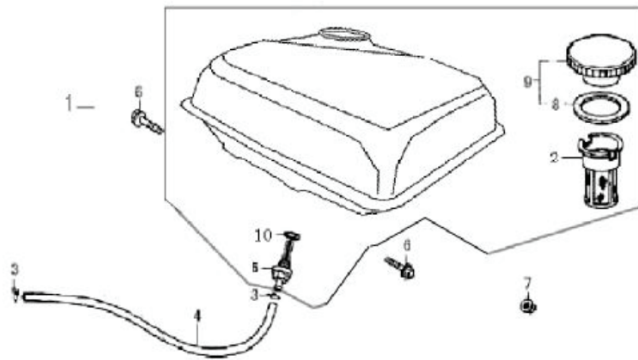

No.	Part No.	Description		QTY.		No.	Part No.	Description		QTY.	
		English		182F(E)	188F(E)			English		182F(E)	188F(E)
1	61100-MB30-0000	FUEL TANK		1	1						
2	61130-MB30-0000	FILTER COMPFUEL		1	1						
3	17020-KB01-0000	CLIP , TUBE		2	2						
4	T2999904500800220	TUBE FUELφ4.5×φ 8× 220		1	1						
5	17006-KB01-0000	JOINT , FUEL TANK		1	1						
6	B057890008002570B	BOLT,FLANGEφ825		2	2						
7	B061770108000060B	NUT,FLANGE,8MM		2	2						
8	61122-KB01-0000	GASKET,FUEL FILLER CAP		1	1						
9	61120-MB30-0000	CAP COMPFUEL FELLER		1	1						

14

Controlled B

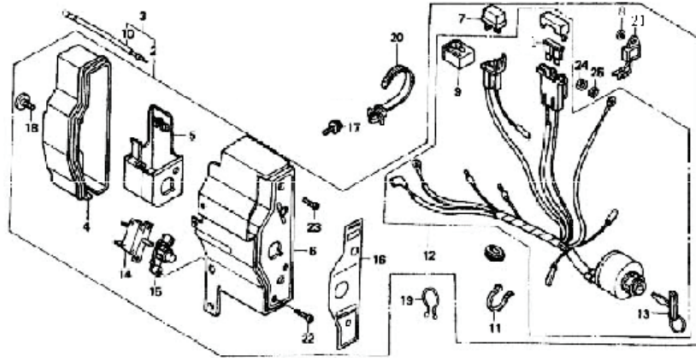

No.	Part No.	Description English	Reqd.No.		No.	Part No.	Description English	Reqd.No.	
			182FE	188FE				182FE	188FE
1	82249-KB12-0000	FUSE	1	1	15	82251-KB12-0000	BUTTON FUSE RENEWED	1	1
2	82240-PB56-0000	CONTROLLED BOX , START	1	1	16	T09999-PB56-0000	LABEL	1	1
3	82240-KB12-0000	CONTROLLER Assy.	1	1	17	B057890006001270B	BOLT , FLANGE , 6× 12	2	2
4	82244-PB56-0000	BACK COVER	1	1	18	B008180005000800B	BOLT , FLANGE , 5× 8	1	1
5	82245-KB12-0000	SKELETON	1	1	19	82253-KB12-0000	CLIP1 , WIRE	1	1
6	82246-PB56-0000	FRONT COVER	1	1	20	82254-KB12-0000	CLIP2 , WIRE	1	1
7	82247-KB12-0000	RECTIFIER B	1	1	21	82248-KB12-0000	RECTIFIER C	1	1
8	B061700005000060B	NUT , FLANGE , M5	1	1	22	B057890004001070B	BOLT , FLANGE , 4× 10	2	2
9	82248-KB12-0000	RECTIFIER C	1	1	23	B008180004001200B	BOLT , FLANGE , 4× 12	1	1
10	82241-KB12-0000	INPUT LINE	1	1	24	B061700005000060B	NUT , FLANGE , 5	1	1
11	82249-KB12-0000	LINE CLIP	1	1	25	B000970205000000B	WASHER φ5	1	1
12	82241-KB12-0000	MODULE CONTROLLED	1	1	26	82250-KB12-0000	FUSE (5A)	1	1
13	TD2002-C04-0000	KEY	2	2					
14	82250-KB12-0000	FUSE RENEWED	1	1					

15

Startup Electromotor Assy

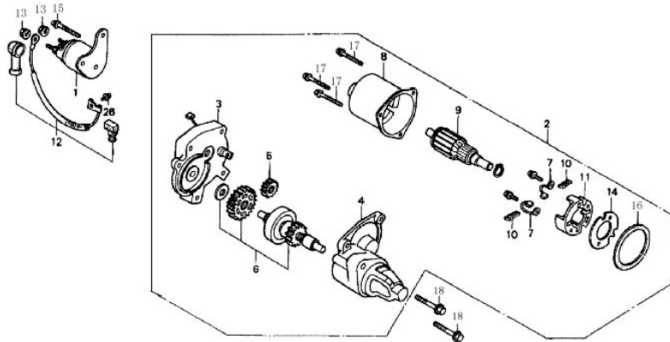

No.	Part No.	Description English	Reqd.No.		No.	Part No.	Description English	Reqd.No.	
			182FE	188FE				182FE	188FE
1	82290-PB56-0000	RELAY STARTING	1	1	15	B057890005003270B	BOLT , FLANGE , 5×32	2	2
2	82230-PB56-0000	STARTUP ELECTROMOTOR	1	1	16	8224G-KB12-0000	WASHER	1	1
3	82234-PB56-0000	COVER ASSY. , MIDDLE	1	1	17	B057890005003270B	BOLT , FLANGE , 5×32	4	4
4	82235-PB56-0000	COVER	1	1	18	B057890008003570B	BOLT , FLANGE , 8×35	2	2
5	82236-PB56-0000	SMALL GEAR	1	1					
6	82237-PB56-0000	PARTS OF APPLIANCE ONE WAY	1	1					
7	82238-PB56-0000	BRUSH,PANEL	2	2					
8	8224E-PB56-0000	STATOR COMP.	1	1					
9	8224F-PB56-0000	ROTOR COMP.	1	1					
10	82239-PB56-0000	BRUSH SPRING	4	4					
11	8224C-PB56-0000	BRUSH FRAME	1	1					
12	82204-KB12-0000	WIRING WATERPROOF	1	1					
13	B061700008000000B	NUT,FLANGE , M5	2	2					
14	8224D-PB56-0000	INSULATION BORD	1	1					

16

Flywheel

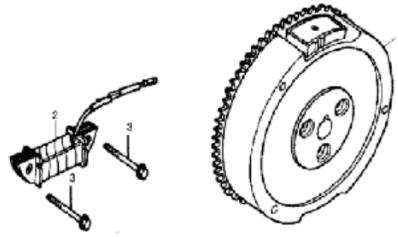

No.	Part No.	Description		QTY		No.	Part No.	Description		QTY	
		English		168FAE	168FBE			English		ZS168FAE	ZS168FBE
1	82150-PB58-0000	FLYWEEL COMP.		1	1						
2	82108-KB12-0000	COIL ASSY. , CHARGE		1	1						
3	B057890006003070B	BOLT, FLANGE , 6x30		2	2						